

EVERLIGHT ELECTRONICS CO.,LTD.

Device Number : DLE-033-734 REV: 1.0

T-1 3/4 (5mm) Round Shape LEDs

MODEL NO : 333-2UYC/S530-A3 ECN : _____ Page: 1/4

Features :

- Popular T-1 3/4 diameter package.
- Choice of various viewing angles.
- Available on tape and reel.
- Reliable and robust.

Description :

- The series is specially designs for applications require higher brightness than that achievable with standard lamp.
- The LED lamps are available with different colors,intensities, epoxy colors, etc.

Package Dimension:

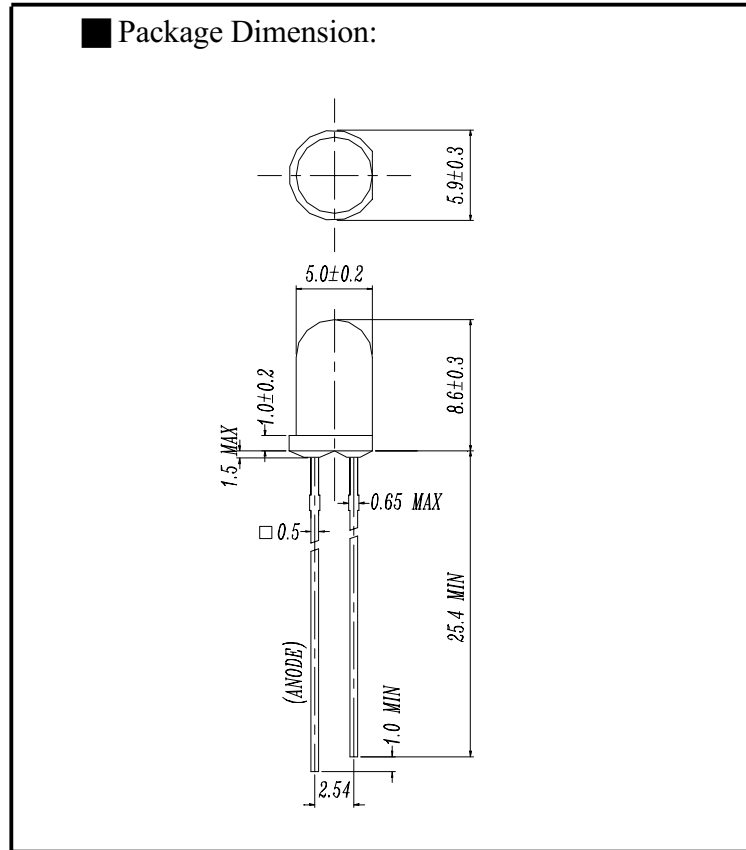

Applications :

- TV Set
- Monitor
- Telephone
- Computer

NOTES :

- 1.All dimensions are in millimeters.
- 2.An epoxy meniscus may extend about 1.5mm(0.059") down to the lead.

PART NO	CHIP		Lens Color
	Material	Emitted Color	
333-2UYC/S530-A3	AlGaInP	Super Yellow	Water Clear

DESIGNER	CHECKER	APPROVER

Office : NO 25,Lane 76,Chung Yang Rd,Sec.3
Tucheng,Taipei 236,Taiwan,R.O.C.

TEL : 886-2-2267-2000,2267-9936(22 Lines)
FAX : 886-2-2267-6189

Device Number : DLE-033-734

REV: 1.0

T-1 3/4 (5mm) Round Shape LEDs

MODEL NO 333-2UYC/S530-A3

ECN : _____

Page: 3/4

■ Typical Electro-Optical Characteristic Curves

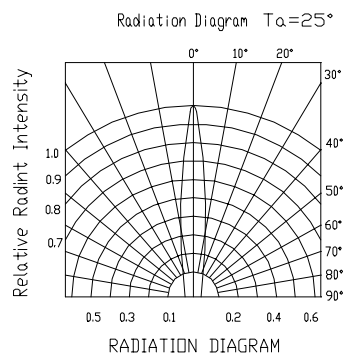
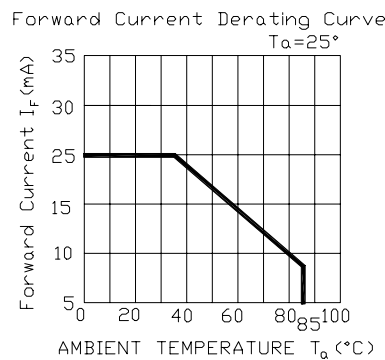
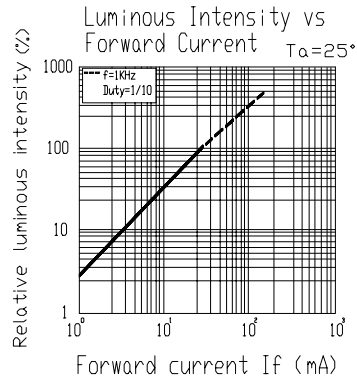
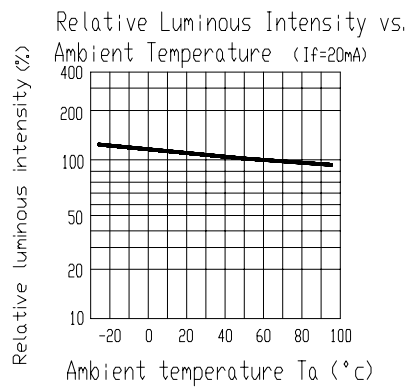
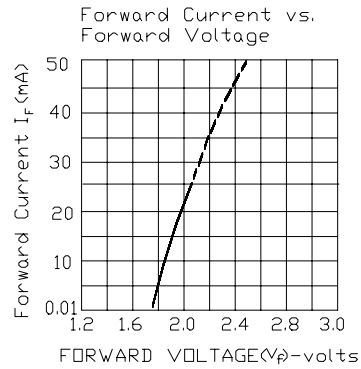
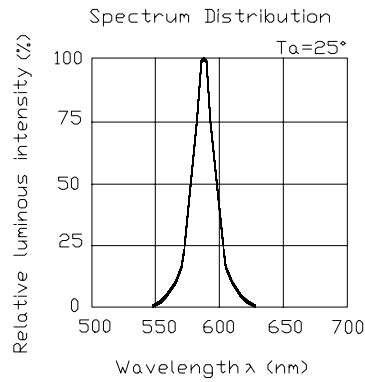

EVERLIGHT ELECTRONICS CO.,LTD.

Device Number : DLE-033-734 REV: 1.0

T-1 3/4 (5mm) Round Shape LEDs

MODEL NO 333-2UYC/S530-A3 ECN : _____ Page: 4/4

■ Reliability test items and conditions

NO	Item	Test Conditions	Test Hours/Cycle	Sample Size	Ac/Re
1	Soldering Heat	TEMP : 260°C ± 5 °C	10±1 SEC	76 Pcs	0/1
2	Solderability	TEMP : 230°C ± 5 °C	5±1 SEC	76 Pcs	0/1
3	Temperature Cycle	H : +85°C 30min ∫ 5 min L : -55°C 30min	50 CYCLE	76 Pcs	0/1
4	Thermal Shock	H : +100°C 5min ∫ 10 sec L : -10°C 5min	50 CYCLE	76 Pcs	0/1
5	High Temperature Storage	TEMP : 100°C	1000 HRS	76 Pcs	0/1
6	Low Temperature Storage	TEMP : -55°C	1000 HRS	76 Pcs	0/1
7	DC Operating Life	If = 20 mA	1000 HRS	76 Pcs	0/1
8	High Temperature / High Humidity	85°C/85% RH	1000 HRS	76 Pcs	0/1