

TOP LEDs

■ **Features :**

- P-LCC-2package.
- White package.
- Optical indicator.
- Colorless clear window.
- Ideal for backlight and light pipe application.
- Inter reflector.
- Low (2mA) current operation.
- Wide viewing angle.
- Computable with automatic placement equipment.
- Suitable for vapor-phase reflow, Infrared reflow and wave solder processes.
- Available on tape and reel (8mm Tape).

■ **Description :**

- The 67-21 series is available in soft-orange, green, blue and yellow, Due to the package design, the LED has wide viewing angle and optimized light coupling by inter reflector, this feature makes the SMT TOP LED ideal for light pipe application, The low current requirement makes this device ideal for portable equipment or any other application where power is at a premium.

■ **Applications :**

- Automotive: backlight in dashboards and switches
- Telecommunication: indicator and backlight in telephone and fax.
- Indicator and backlight for audio and video equipment.
- Indicator and backlight in office and family equipment.
- Flat backlight for LCD's, switches and symbols.
- Light pipe application.
- General use.

■ **Package Dimension :**

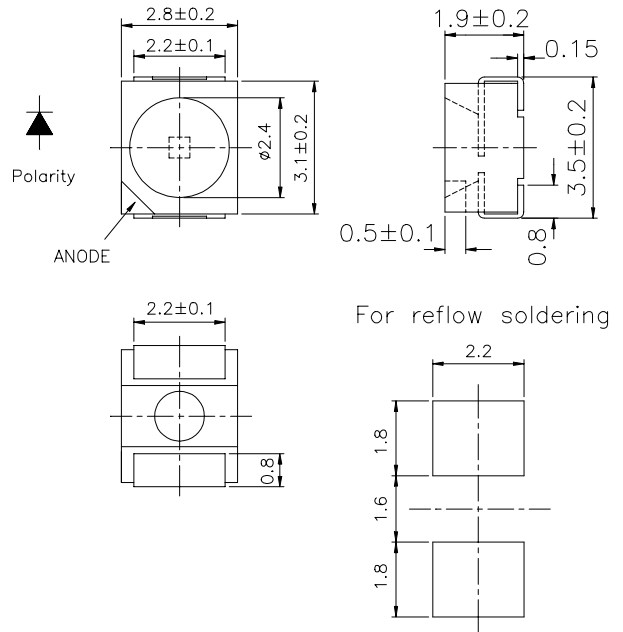

■ **Notes:**

Tolerances Unless Dimension ± 0.1 mm
 Angle $\pm 0.5^\circ$
 Unit = mm

PART NO	CHIP		Lens Color
	Material	Emitted Color	
67-21SUGC/TR8	GaN	Super Green	Water Clear

TOP LEDs

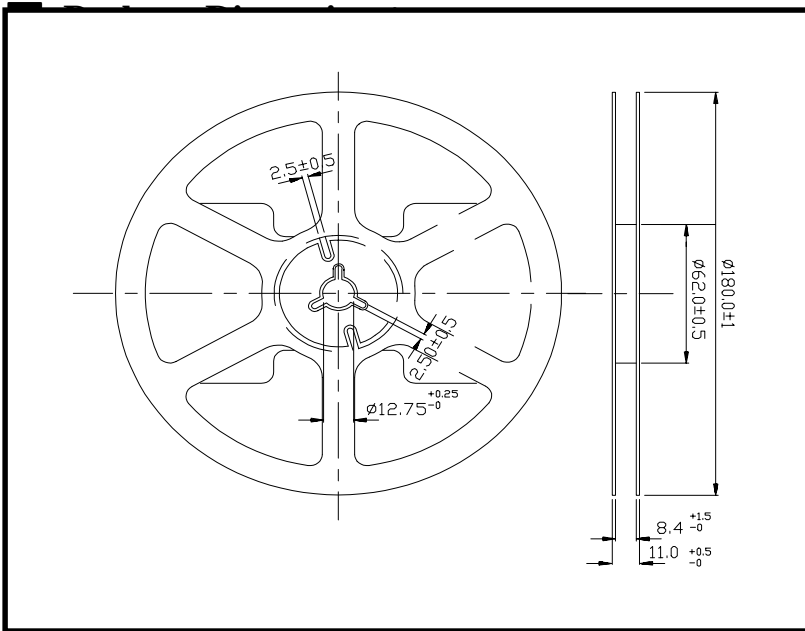

Loaded quantity per reel 2000 pcs/reel :

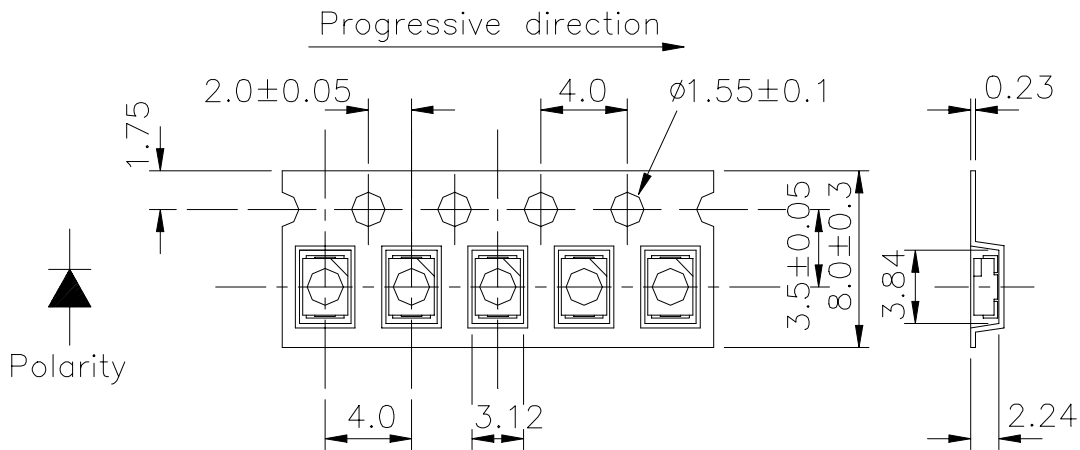

TOLERANCES UNLESS DIMENSION ± 0.1
 ANGLE ± 0.5
 UNIT:mm

■ Reliability Test Item And Condition

NO	Item	Test Conditions	Test Hours/Cycle	Sample Size	Ac/Re
1	Solder Heat	TEMP : 260°C ± 5 °C	5 SEC	76 Pcs	0/1
2	Temperature Cycle	H : +85°C 30min ∩ 5 min L : -55°C 30min	50 CYCLE	76 Pcs	0/1
3	Thermal Shock	H : +100°C 5min ∩ 10 sec L : -10°C 5min	50 CYCLE	76 Pcs	0/1
4	High Temperature Storage	TEMP : 100°C	1000 HRS	76 Pcs	0/1
5	High Temperature Storage	TEMP : -55°C	1000 HRS	76 Pcs	0/1
6	DC Operating Life	If = 20 mA	1000 HRS	76 Pcs	0/1
7	High Temperature / High Humidity	85°C/85% RH	1000 HRS	76 Pcs	0/1

Products are evaluated according to the above standard reliability criteria.

TOP LEDs

Typical Electro-Optical Characteristic Curves

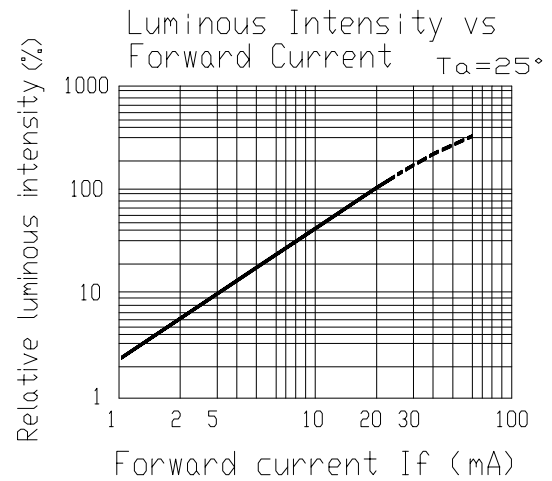
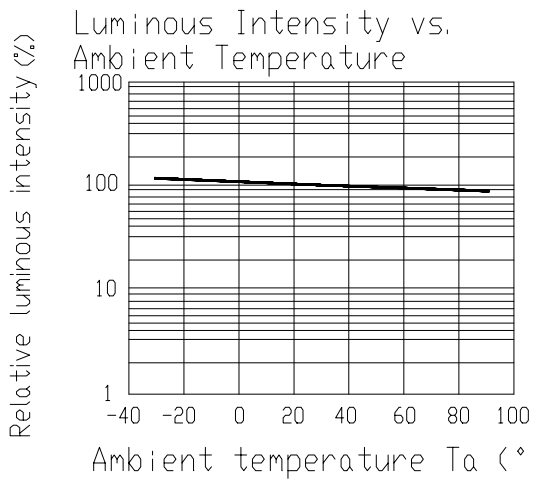
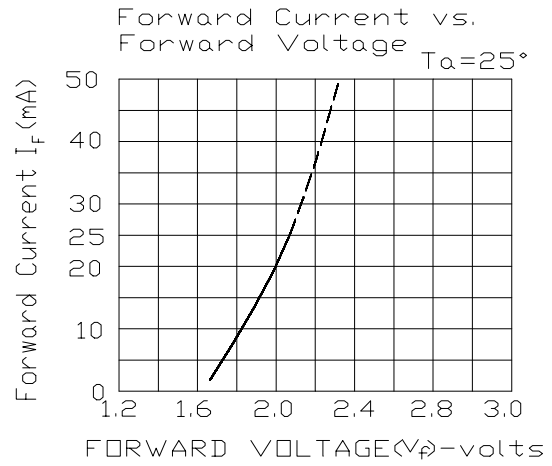
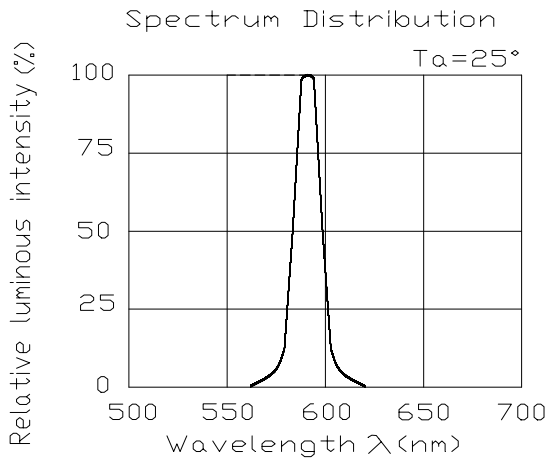

Forward Current Derating Curve

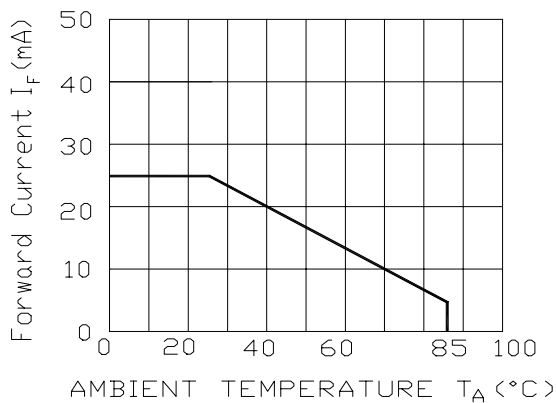

Radiation Diagram Ta=25°

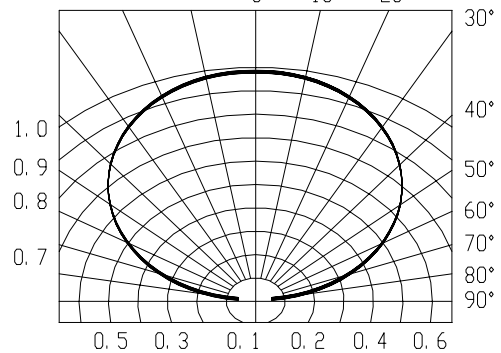

■ Soldering heat reliability (DIP)

Please refer to the following figure :

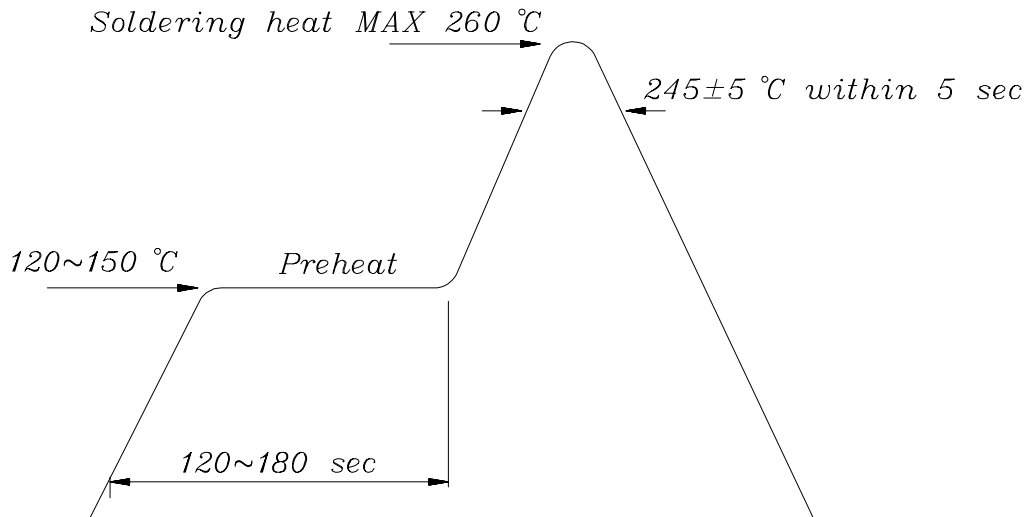

■ Soldering Iron

Basic spec is ≤ 5 sec when 260°C. If temperature is higher, time should be shorter (+10°C → -1sec). Power dissipation of Iron should be smaller than 15 W , and temperature should be controllable. Surface temperature of the device should be under 230 °C.

■ Rework

1. Customer must finish rework within 5 sec under 260°C .
2. The head of iron can not touch copper foil.
3. Twin-head type is preferred.

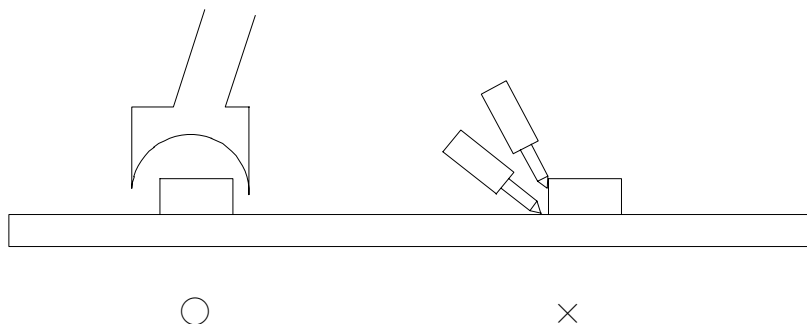

TOP LEDs

■ **Reflow Temp / Time :**

