

DATA SHEET

PART NO. : 15-21/BHC-AN1P2/2T

DATE : 2003/1/10

DEPARTMENT : R.D.1

REVISION : 1.0

RECEIVED			
<input checked="" type="checkbox"/> MASS PRODUCTION			
<input type="checkbox"/> PRELIMINARY			
<input type="checkbox"/> CUSTOMER DESIGN			
DEVICE NUMBER : DSE-151-B01			
PAGE : 12			
CUSTOMER	DESIGNER	CHECKER	APPROVER
	Jessica Chang	Jeff Tsai	Charles Chang

-	DESCRIPTION	RELEASE DATE

Package Type:

SMD For PCB Type

11-21	19-215
12-21	19-215A
12-215	19-217A
15-21	22-21
15-215	23-21
16-213	23-21B
17-21	24-21
17-215	25-21
19-21	27-21
19-21A	42-21

Dominant Wavelength Groups:

According to the difference wavelength to define

None: No definition

- A : Standard wavelength definition.
- B : Range of wavelength definition is more narrowly than group A.
- C : Range of wavelength definition is more narrowly than group A, but the value is different with group B.
- F : The wavelength definition in special specification.

The dominant wavelength data did not including ±1nm testing tolerance.

Test Forward Current:

- None: 20 mA
- Y : 5 mA
- Z : 10 mA

Taping Quantity:

- 1: 1000 pcs (Taping)
- 2: 2000 pcs (Taping)
- 3: 3000 pcs (Taping)
- 5: 5000 pcs (Taping)
- C : 1500 pcs (Taping)
- D : 10000 pcs (Taping)

Packing Method :

- A: Reverse-side placement
- B: Reverse-side placement (Anode toward the sprocket hole)
- C: Right-side placement
- D: Right-side placement (Anode toward the sprocket hole)
- T: Top-side placement
- R: Top-side placement (Anode toward the sprocket hole)

3 T

Emission Color:

R: Red

(λ d:640nm,630nm,625nm)

S: Sunset Orange

(λ d:615nm,605nm)

Y: Yellow

(λ d:595nm,590nm)

G: Green

(λ d:570nm,565nm,560nm,525nm,505nm)

B: Blue

(λ d:470nm)

W: White x=0.32 y=0.31

The ordinal number that base on difference electro-optical characteristics within chip.

1,2 7,8,9, A,B X,Y,Z

Resin Color:

- C: Water Clear
- W: White Diffused
- D: Diffused

Luminous Intensity Groups:

- C0: 0.28 ... 0.45
- D0: 0.45 ... 0.70
- E0: 0.70 ... 1.1
- F0: 1.1 ... 1.8
- G0: 1.8 ... 2.8
- H0: 2.8 ... 4.5
- J0: 4.5 ... 7.2
- K0: 7.2 ... 11.5
- L1: 11.5 ... 14.5
- L2: 14.5 ... 18.0
- M1: 18.0 ... 22.5
- M2: 22.5 ... 28.5
- N1: 28.5 ... 36.0
- N2: 36.0 ... 45.0
- P1: 45.0 ... 57.0
- P2: 57.0 ... 72.0
- Q1: 72.0 ... 90.0
- Q2: 90.0 ... 112

- R ⇨ R1: 112 ... 140
- R2: 140 ... 180
- S ⇨ S1: 180 ... 225
- S2: 225 ... 285
- T ⇨ T1: 285 ... 360
- T2: 360 ... 450
- U ⇨ U1: 450 ... 565
- U2: 565 ... 715
- V ⇨ V1: 715 ... 900
- V2: 900 ... 1120
- W ⇨ W1: 1120 ... 1420
- W2: 1420 ... 1800
- X ⇨ X1: 1800 ... 2250
- X2: 2250 ... 2850
- Y ⇨ Y1: 2850 ... 3600
- Y2: 3600 ... 4500

www.nscn.com.cn

The luminous intensity data did not including ±15% testing tolerance.

Unit: mcd

Forward Voltage Groups:

None: No definition

The VF definition as follows:

Forward Voltage Group	Bin	Unit: V		
		Min.	Max.	
C	00	1.55	1.75	
	A	0	1.75	1.95
	B	1	1.95	2.15
	1	2	2.15	2.35
	2	3	2.35	2.55
M	3	2.35	2.55	
	4	2.55	2.75	
	5	2.75	3.05	
	6	3.05	3.35	
	7	3.35	3.65	
	8	3.65	3.95	
	9	2.50	2.70	
	10	2.70	2.90	
N	11	2.90	3.10	
	12	3.10	3.30	
	13	3.30	3.50	
	14	3.50	3.70	
P	15	2.70	2.85	
	16	2.85	3.00	
	17	3.00	3.15	
	18	3.15	3.30	

The forward voltage data did not including ±0.1V testing tolerance.

■ Dominant Wavelength Groups:

B1				
Dom . Wavelength	Range			
Of Group	Bin	Min.	Max.	Unit
A	A7	458.5	461.5	nm
	A8	461.5	464.5	nm
	A9	464.5	467.5	nm
	A10	467.5	470.5	nm
	A11	470.5	473.5	nm
	A12	473.5	476.5	nm

B3				
Dom . Wavelength	Range			
Of Group	Bin	Min.	Max.	Unit
A	A8	461.5	464.5	nm
	A9	464.5	467.5	nm
	A10	467.5	470.5	nm
	A11	470.5	473.5	nm
	A12	473.5	476.5	nm
	A13	476.5	479.5	nm

BL				
Dom . Wavelength	Range			
Of Group	Bin	Min.	Max.	Unit
A	A5	452.5	455.5	nm
	A6	455.5	458.5	nm
	A7	458.5	461.5	nm
	A8	461.5	464.5	nm
	A9	464.5	467.5	nm

BH						
Dom . Wavelength			Range			
Of Groups			Bin	Min.	Max.	Unit
A	A	A	A9	464.5	467.5	nm
			A10	467.5	470.5	nm
			A11	470.5	473.5	nm
			A12	473.5	476.5	nm
V	Z	X	X	465	470	nm
			Y	470	475	nm
		W	475	480	nm	

■ Forward Voltage Groups:

Forward Voltage Groups				Range				
				Bin	Min.	Max.	Unit	
C	B	A	00	1.55	1.75	v		
			0	1.75	1.95	v		
		1	1.95	2.15	v			
		2	2.15	2.35	v			
		3	2.35	2.55	v			
	M	E	D	4	2.55	2.75	v	
				5	2.75	3.05	v	
				6	3.05	3.35	v	
				7	3.35	3.65	v	
				8	3.65	3.95	v	
N	F	K	R	J	9	2.50	2.70	v
					10	2.70	2.90	v
					11	2.90	3.10	v
	P	H	12	3.10	3.30	v		
			13	3.30	3.50	v		
			14	3.50	3.70	v		
P	H	15	2.70	2.85	v			
		16	2.85	3.00	v			
		17	3.00	3.15	v			
		18	3.15	3.30	v			

Technical Data Sheet

1206 Package Chip LED

Features

- Package in 8mm tape on 7" diameter reel.
- Compatible with automatic placement equipment.
- Compatible with infrared and vapor phase reflow solder process.
- Mono-color type.

Descriptions

- The 15-21 SMD Taping is much smaller than lead frame type components, thus enable smaller board size, higher packing density, reduced storage space and finally smaller equipment to be obtained.
- Besides, lightweight makes them ideal for miniature applications. etc.

Applications

- Automotive: backlighting in dashboard and switch.
- Telecommunication: indicator and backlighting in telephone and fax.
- Flat backlight for LCD, switch and symbol.
- General use.



Device Selection Guide

Part No.	Chip		Lens Color
	Material	Emitted Color	
15-21/B1C	GaN/SiC	Purplish Blue	Water Clear
15-21/B3C	InGaN/SiC	Blue	
15-21/BLC	InGaN	Deep-Blue	
15-21/BHC		Blue *2	

*1. The series is included 15-21/B1C,15-21/B3C,15-21/BLC, and 15-21/BHC.

*2. Emitted color is distinguished to Dark Blue and Brilliant Blue.

Package Outline Dimensions

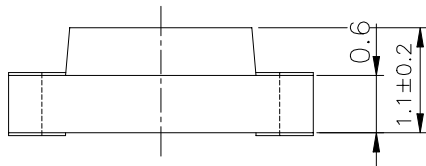
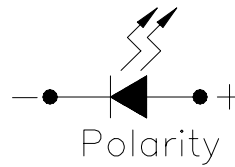
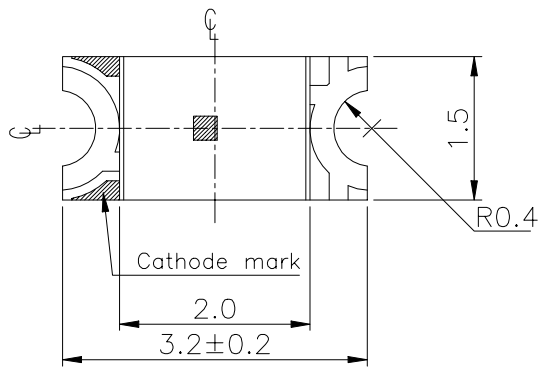

For reflow soldering (propose)

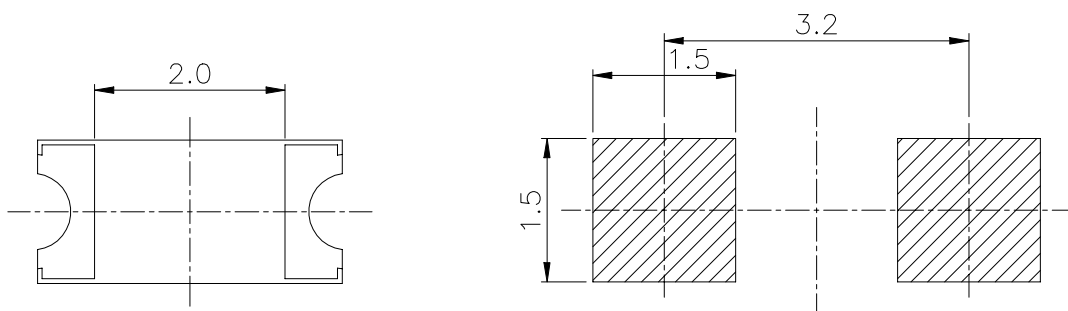

Note: The tolerances unless mentioned is $\pm 0.1\text{mm}$, Angle $\pm 0.5^\circ$,Unit = mm

Absolute Maximum Ratings (Ta=25°C)

Series	Parameter	Symbol	Rating	Unit
15-21/B_C Series	Reverse Voltage	V _R	5	V
15-21/B_C Series	Forward Current	I _F	25	mA
15-21/B1C/B3C			30	
15-21/B_C Series	Operating Temperature	T _{opr}	-40 ~ +85	°C
15-21/B_C Series	Storage Temperature	T _{stg}	-40 ~ +90	°C
15-21/B_C Series	Soldering Temperature	T _{sol}	260 (for 5 seconds)	°C
15-21/B_C Series	Electrostatic Discharge	ESD	150	V
15-21/B1C/B3C			1000	
15-21/B_C Series	Power Dissipation	P _d	110	mW
15-21/B1C/B3C			130	
15-21/B_C Series	Peak Forward Current (Duty 1/10 @1KHz)	I _F	100	mA
15-21/B1C			70	

Electro-Optical Characteristics (Ta=25°C)

Part No.	Parameter	Symbol	Min.	Typ.	Max.	Unit	Condition
15-21/B1C	Peak Wavelength	λ_p	----	428	----	nm	If=20mA
15-21/B3C				468			
15-21/BLC				465			
15-21/BHC				468			
15-21/B1C	Dominant Wavelength	λ_d	----	466	----	nm	
15-21/B3C				470			
15-21/BLC				460			
15-21/BHC				470			
15-21/B1C	Spectrum Radiation Bandwidth	$\Delta \lambda$	----	65	----	nm	
15-21/B3C				26			
15-21/BLC				25			
15-21/BHC				25			
15-21/B_C Series	Viewing Angle	$2\theta_{1/2}$	----	130	----	deg	
15-21/B_C Series	Forward Voltage	V_F	----	3.5	4.0	V	
15-21/B1C				3.8	4.5		
15-21/B_C Series	Reverse Current	I_R	----	----	50	μA	$V_R=5V$

Notes:

- 1. Tolerance of Forward Voltage $\pm 0.1V$**

■ 15-21/B__C Series Explain Of Luminous Intensity:

I_F=20mA

Part No.	Parameter	Symbol	Typ.	Bin Code	Min.	Max.	Unit
15-21/B1C-M1N2	Luminous Intensity	I _v	28	M1	18.0	22.5	mcd
				M2	22.5	28.5	
				N1	28.5	36.0	
				N2	36.0	45.0	
15-21/B3C-M1N2	Luminous Intensity	I _v	26	M1	18.0	22.5	mcd
				M2	22.5	28.5	
				N1	28.5	36.0	
				N2	36.0	45.0	
15-21/BLC-L2N1	Luminous Intensity	I _v	20	L2	14.5	18.0	mcd
				M1	18.0	22.5	
				M2	22.5	28.5	
				N1	28.5	36.0	
15-21/BHC-N1P2	Luminous Intensity	I _v	40	N1	28.5	36.0	mcd
				N2	36.0	45.0	
				P1	45.0	57.0	
				P2	57.0	72.0	
15-21/BHC-N2P2	Luminous Intensity	I _v	55	N2	36.0	45.0	mcd
				P1	45.0	57.0	
				P2	57.0	72.0	

Note:

The luminous intensity data did not including $\pm 15\%$ testing tolerance.

■ 15-21/B__C Series Explain Of Luminous Intensity:

I_F=10mA

Part No.	Parameter	Symbol	Typ.	Bin Code	Min.	Max.	Unit
15-21/BHC-LN	Luminous Intensity	I _v	22	L	11.5	18.0	mcd
				M	18.0	28.5	
				N	28.5	45.0	
15-21/BHC-MN	Luminous Intensity	I _v	30	M	18.0	28.5	mcd
				N	28.5	45.0	

I_F=5mA

Part No.	Parameter	Symbol	Typ.	Bin Code	Min.	Max.	Unit
15-21/BHC-K0M	Luminous Intensity	I _v	12	K0	7.2	11.5	mcd
				L	11.5	18.0	
				M	18.0	28.5	
15-21/BHC-LM	Luminous Intensity	I _v	17	L	11.5	18.0	mcd
				M	18.0	28.5	

Note:

The luminous intensity data did not including $\pm 15\%$ testing tolerance.

Typical Electro-Optical Characteristics Curves

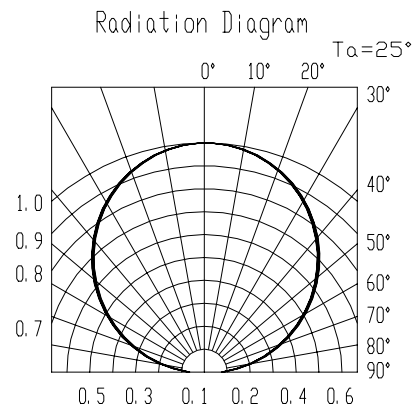
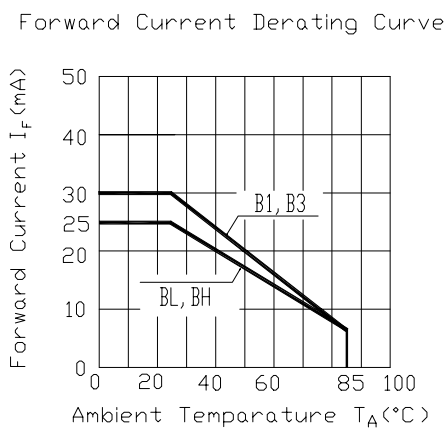
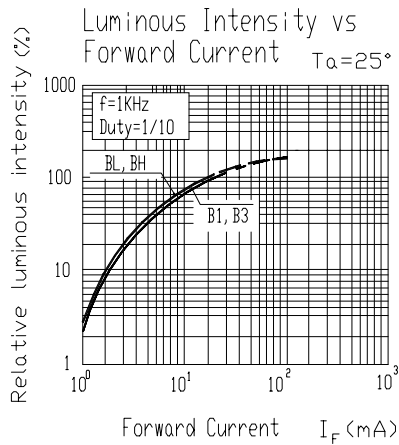
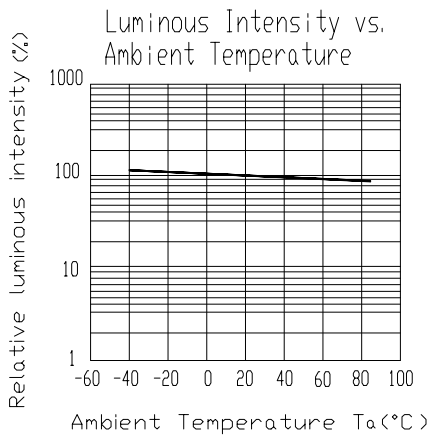
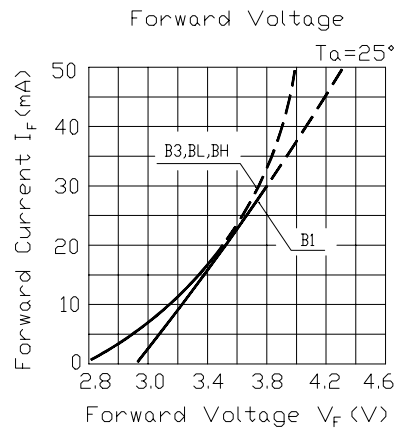
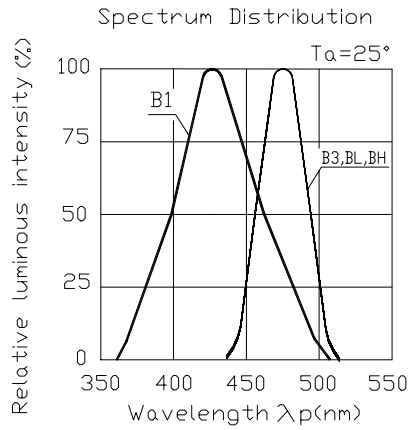

Label explanation

CAT: Luminous Intensity (mcd)

HUE: Dom. Wavelength (nm)

REF: Forward Voltage (V)

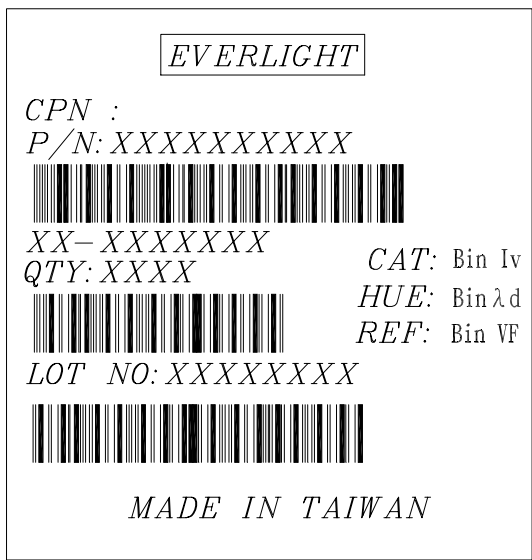

Reel Dimensions

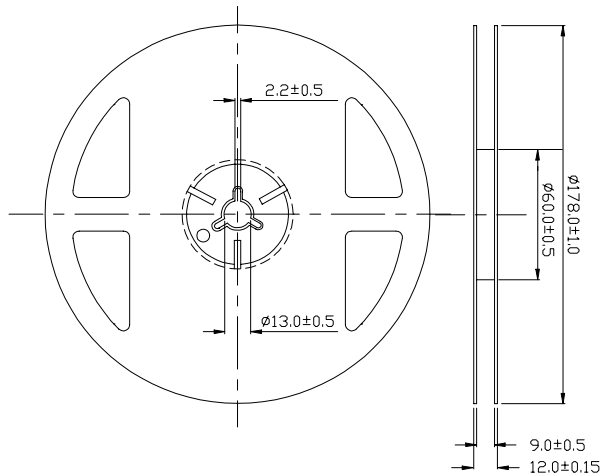

Taping Quantity: 3000pcs

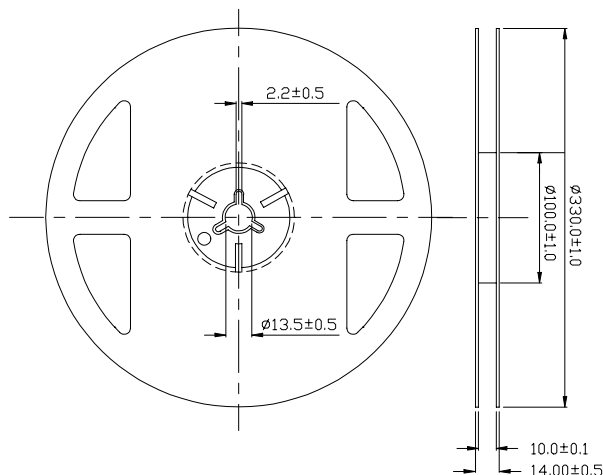

Taping Quantity: 5000pcs & 10000pcs

Note: The tolerances unless mentioned is $\pm 0.1\text{mm}$, Angle $\pm 0.5^\circ$,Unit = mm

Carrier Tape Dimensions

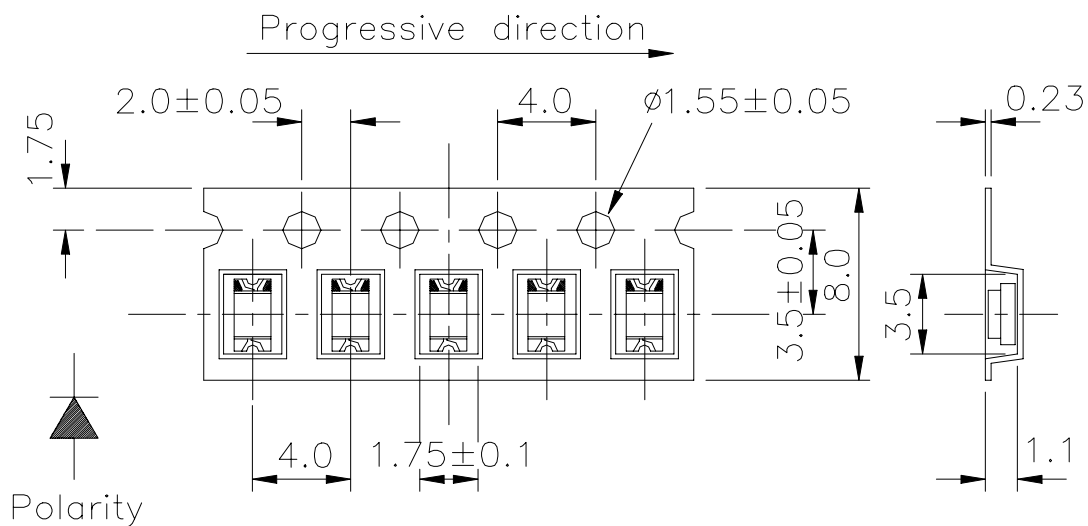

Note: The tolerances unless mentioned is $\pm 0.1\text{mm}$, Angle $\pm 0.5^\circ$,Unit = mm

Moisture Resistant Packaging

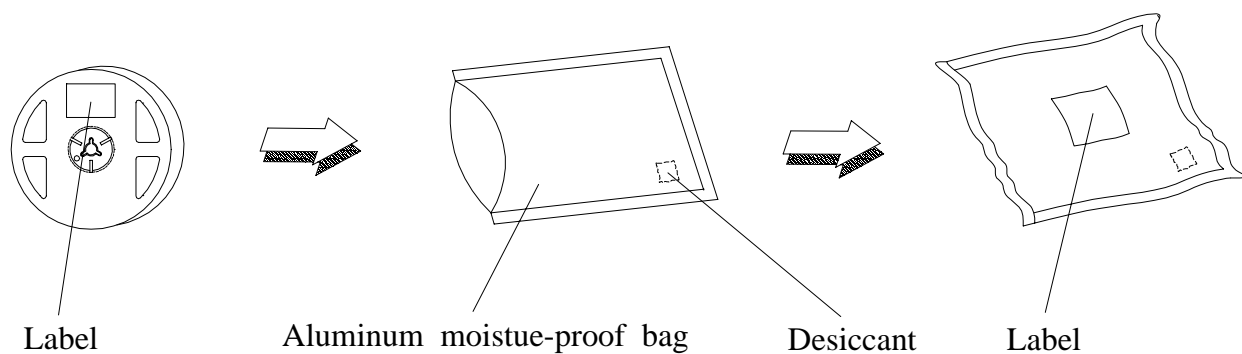

Reliability Test Items And Conditions

The reliability of products shall be satisfied with items listed below.

Confidence level : 90 %

LTPD : 10 %

No.	Items	Test Condition	Test Hours/Cycles	Sample Size	Ac/Rc
1	Reflow	Temp. : 240°C ± 5°C Min. 5 sec.	6 min.	22 Pcs.	0/1
2	Temperature Cycle	H : +100°C 15 min. § 5 min. L : -40°C 15 min.	300 Cycles	22 Pcs.	0/1
3	Thermal Shock	H : +100°C 5 min. § 10 sec. L : -10°C 5 min.	300 Cycles	22 Pcs.	0/1
4	High Temperature Storage	Temp. : 100°C	1000 Hrs.	22 Pcs.	0/1
5	Low Temperature Storage	Temp. : -55°C	1000 Hrs.	22 Pcs.	0/1
6	DC Operating Life	IF = 20 mA	1000 Hrs.	22 Pcs.	0/1
7	High Temperature / High Humidity	85°C/RH 85%	1000 Hrs.	22 Pcs.	0/1

Precautions For Use

1. Over-current-proof

Customer must apply resistors for protection , otherwise slight voltage shift will cause big current change (Burn out will happen).

2. Storage time

2.1 The operation of Temperature and RH are : 5°C~35°C, RH60%.

2.2 Once the package is opened, the products should be used within a week. Otherwise, they should be kept in a damp proof box with desiccating agent. Considering the tape life , we suggest our customers to use our products within a year(from production date).

2.3 If opened more than one week in an atmosphere 5°C~35°C, RH 60%, they should be treated at 60°C± 5°C for 15hrs.

2.4 When you discover that the desiccant in the package has a pink color (Normal = blue) , you should treat them in the same conditions as 2.3.

Soldering heat

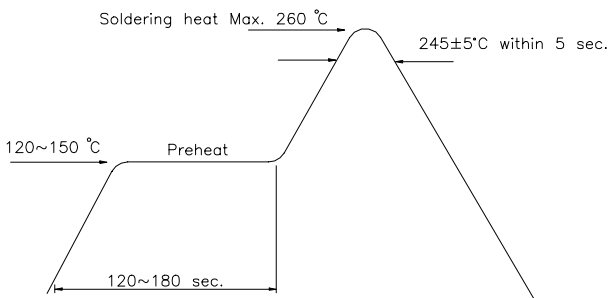

Reflow Temp / Time

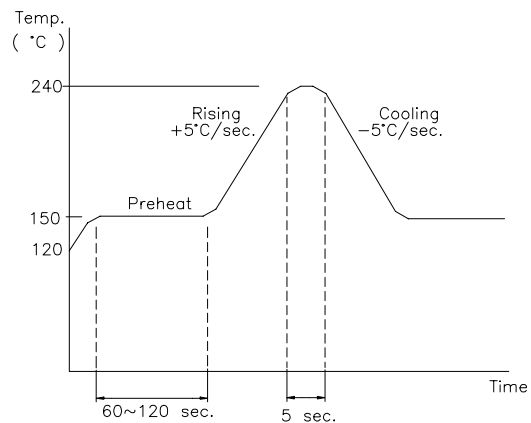

Soldering Iron

Basic spec is ≤5 sec when 260°C. If temperature is higher, time should be shorter (+10°C → -1sec). Power dissipation of Iron should be smaller than 15 W , and temperature should be controllable. Surface temperature of the device should be under 230 °C .

Rework

1. Customer must finish rework within 5 sec under 245°C.
2. The head of iron can not touch copper foil.
3. Twin-head type is preferred.

