

SAW-Based Differential Multi Output (LV-PECL) : MG7050EAN

Features

- Ultra Low jitter : 0.3 ps Max.
- 2 or 4 outputs and it is able to reduce fan-out buffers
- Frequency range : 100 MHz to 700 MHz
- Supply voltage : 2.5 V / 3.3 V
- External dimensions : 7.0 × 5.0 × 1.6 mm
- Output : LV-PECL (2 or 4 outputs)
- Pb free.
- Complies with EU RoHS directive.



Applications

- GbE, Fiber Channel, SAS, PCI express
- Server, Storage, Router/Switch,
- Networking, OTN etc.

Description

This product is high frequency oscillator of LV-PECL outputs using fundamental oscillation of SAW resonator. This has realized a low-jitter and low noise in frequency 100 to 700 MHz, and is suitable for the reference clock include PCI Express and others.

Block Diagram

2 outputs

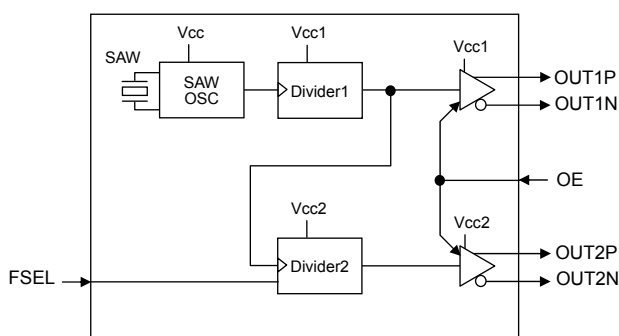

4 outputs

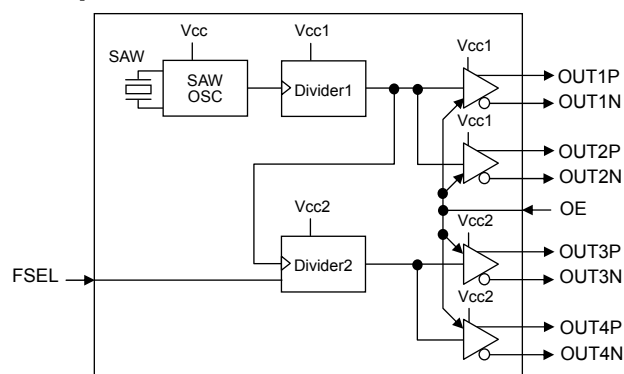

Notice

- This material is a manual for the product and does not guarantee the specification of product.
- This material is subject to change without notice.
- Any part of this material may not be reproduced or duplicated in any form or any means without the written permission of Seiko Epson.
- The information, applied circuitry, programming, usage, etc., written in this material is intended for reference only. Seiko Epson does not assume any liability for the occurrence of infringing on any patent or copyright of a third party. This material does not authorize the licensing for any patent or intellectual copyright.
- Any product described in this material may contain technology or the subject relating to strategic products under the control of the Foreign Exchange and Foreign Trade Law of Japan and may require an export license from the Ministry of International Trade and Industry or other approval from another government agency.
- These products are intended for general use in electronic equipment. When using them in specific applications that require extremely high reliability, such as the applications stated below, you must obtain permission from Seiko Epson in advance.
 - /Space equipment (artificial satellites, rockets, etc.)
 - /Transportation vehicles and related (automobiles, aircraft, trains, vessels, etc.)
 - /Medical instruments to sustain life
 - /Submarine transmitters
 - /Power stations and related
 - /Fire work equipment and security equipment
 - /Traffic control equipment /and others requiring equivalent reliability.
- The manual does not guarantee the specification of product.

1. Electrical characteristics

1) Absolute maximum ratings

Parameter	Symbol	Unit	Min.	Typ.	Max	Notes
Supply voltage	V _{CC}	V	-0.5	-	+4.0	
Storage temperature	T _{STG}	°C	-55	-	+125	Store as bare product after packing
Input voltage	V _{IN}	V	-0.5	-	V _{CC} +0.5	

2) Operating conditions

Parameter	Symbol	Unit	Min.	Typ.	Max	Notes
Supply voltage	V _{CC}	V	2.97	3.3	3.63	Part C
			2.375	2.5	2.625	Part D
Output frequency	f _o	MHz	100	-	700	FSEL=LOW 2-outputs: OUT2 4-outputs: OUT3,OUT4
			50	-	350	
Operating temperature range	T _{use}	°C	0	-	+70	Part A
			-20	-	+70	Part B
			-5	-	+85	Part D
Output load condition	L_ECL	Ω	50			Terminated to V _{CC} -2 V

3) Frequency characteristics

Parameter	Symbol	Unit	Min.	Typ.	Max	Notes
Frequency tolerance	f _{tol}	× 10 ⁻⁶	-50	-	+50	Part J
			-100	-	+100	Part L
Frequency aging	f _{age}	× 10 ⁻⁶	-10	-	+10	Part N
			Include on frequency tolerance			Part A *1

*1 "A" is not acceptable when Frequency tolerance is "J" and Operating temperature is "B" or "D".

4) Characteristics

[GND=0.0 V]

Parameter	Symbol	Unit	Min.	Typ.	Max	Notes
Oscillation start up time	T _{str}	ms	-	5	10	
Current consumption	I _{CC}	mA	-	80	102	V _{CC} =3.3V, 2-outputs
			-	130	184	V _{CC} =3.3V, 4-outputs
			-	75	94	V _{CC} =2.5V, 2-outputs
			-	125	170	V _{CC} =2.5V, 4-outputs
Disable current	I _{dis}	mA	-	8	20	V _{CC} =3.3V
			-	7	18	V _{CC} =2.5V
Rise time	t _r	ps	-	200	400	20% → 80% of (V _{OH} -V _{OL})
Fall time	t _f	ps	-	200	400	80% → 20% of (V _{OH} -V _{OL})
Symmetry	SYM	%	45	50	55	
High output voltage	V _{OH}	V	V _{CC} -1.025	V _{CC} -0.955	V _{CC} -0.88	DC characteristics
Low output voltage	V _{OL}	V	V _{CC} -1.81	V _{CC} -1.705	V _{CC} -1.62	DC characteristics
High input voltage	V _{IH}	V	70 %V _{CC}	-	V _{CC} +0.3	OE, FSEL terminal
Low Input voltage	V _{IL}	V	-0.3	-	30 %V _{CC}	OE, FSEL terminal
Input current	I _{IH}	μA	-	-	2	V _{IN} =V _{CC} , OE, FSEL terminal
			-60	-	-20	V _{CC} =3.3V
	I _{IL}	-45	-	-15	V _{CC} =2.5V	V _{IN} =GND
Disable delay time	t _{pxz}	ns	-	-	100	OE terminal "H" → "L"
Enable delay time	t _{pzx}	ns	-	-	100	OE terminal "L" → "H"
Skew	t _{skew}	ps	-	20	50	
Phase Jitter *2	t _{PJ}	ps	-	0.14(0.17)	0.3	f ₀ =100MHz, V _{CC} =3.3V(2.5V)
			-	0.13(0.16)		f ₀ =125MHz, V _{CC} =3.3V(2.5V)
			-	0.12(0.15)		f ₀ =156.25MHz, V _{CC} =3.3V(2.5V)
			-	0.11(0.13)		f ₀ =212.5MHz, V _{CC} =3.3V(2.5V)
			-	0.10(0.11)		f ₀ =312.5MHz, V _{CC} =3.3V(2.5V)
			-	0.05(0.05)		f ₀ =700MHz, V _{CC} =3.3V(2.5V)
			-	-	0.5	FSEL=LOW, 50 MHz ≤ f _o < 100 MHz 2-outputs: OUT2 4-outputs: OUT3,OUT4

*2 Offset frequency: 12 kHz to 20 MHz

2. Outline

2-1) Outline dimensions and Pin information

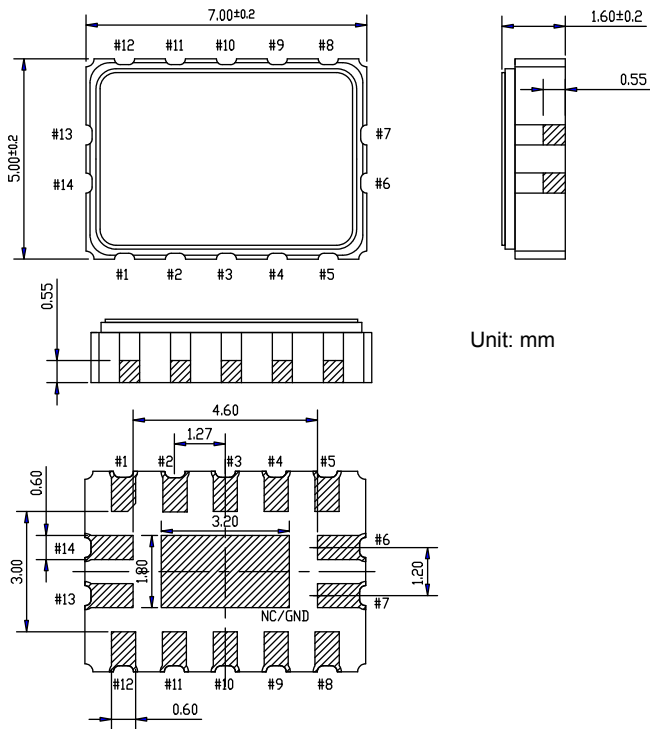

Pin	Connections	
	2-outputs	4-outputs
1	V _{CC1}	
2	GND	OUT1P
3	OUT1P	OUT1N
4	OUT1N	OUT2P
5	GND	OUT2N
6	FSEL	
7	OE	
8	GND	OUT3N
9	OUT2N	OUT3P
10	OUT2P	OUT4N
11	GND	OUT4P
12	V _{CC2}	
13	V _{CC}	
14	GND	

2-2) Pin map and Function of terminals

2-outputs

Connection	No.	Type	Remarks									
Vcc1	1	-	Vcc pin (for OUT1)									
GND	2	-	GND pin									
OUT1P	3	OUTPUT	Output pin									
OUT1N	4	OUTPUT	Output pin, inversion of #3									
GND	5	-	GND pin									
FSEL	6	INPUT	Frequency select pin for OUT2. As per below. “H” : same as OUT1 “L” : half of OUT1									
OE	7	INPUT	Output enable pin. As per below table.									
			<table border="1"> <thead> <tr> <th>Input level</th> <th>Oscillation</th> <th>Outputs</th> </tr> </thead> <tbody> <tr> <td>“H”</td> <td>Enable</td> <td>Enable : specified frequency</td> </tr> <tr> <td>“L”</td> <td>Enable</td> <td>Disable : Hi-Z</td> </tr> </tbody> </table>	Input level	Oscillation	Outputs	“H”	Enable	Enable : specified frequency	“L”	Enable	Disable : Hi-Z
			Input level	Oscillation	Outputs							
“H”	Enable	Enable : specified frequency										
“L”	Enable	Disable : Hi-Z										
GND	8	-	GND pin									
OUT2N	9	OUTPUT	Output pin, inversion of #10									
OUT2P	10	OUTPUT	Output pin									
GND	11	-	GND pin									
Vcc2	12	-	Vcc pin (for OUT2)									
Vcc	13	-	Vcc pin (for Oscillation circuit)									
GND	14	-	GND pin									

4-outputs

Connection	No.	Type	Remarks									
Vcc1	1	-	Vcc pin (for OUT1,OUT2)									
OUT1P	2	OUTPUT	Output pin									
OUT1N	3	OUTPUT	Output pin, inversion of #2									
OUT2P	4	OUTPUT	Output pin									
OUT2N	5	OUTPUT	Output pin, inversion of #4									
FSEL	6	INPUT	Frequency select pin for OUT3 and OUT4. As per below. “H” : same as OUT1,OUT2 “L” : half of OUT1,OUT2									
OE	7	INPUT	Output enable pin. As per below table.									
			<table border="1"> <thead> <tr> <th>Input level</th> <th>Oscillation</th> <th>Outputs</th> </tr> </thead> <tbody> <tr> <td>“H”</td> <td>Enable</td> <td>Enable : specified frequency</td> </tr> <tr> <td>“L”</td> <td>Enable</td> <td>Disable : Hi-Z</td> </tr> </tbody> </table>	Input level	Oscillation	Outputs	“H”	Enable	Enable : specified frequency	“L”	Enable	Disable : Hi-Z
			Input level	Oscillation	Outputs							
“H”	Enable	Enable : specified frequency										
“L”	Enable	Disable : Hi-Z										
OUT3N	8	OUTPUT	Output pin, inversion of #9									
OUT3P	9	OUTPUT	Output pin									
OUT4N	10	OUTPUT	Output pin, inversion of #11									
OUT4P	11	OUTPUT	Output pin									
Vcc2	12	-	Vcc pin (for OUT3,OUT4)									
Vcc	13	-	Vcc pin (for Oscillation circuit)									
GND	14	-	GND pin									

* The metal part of the surface (metal cap) and the center electrode of the pin side are connected to GND(#14).

* The center electrode of the pin side is non-connection or GND.

* Unused output pairs may be left floating.

2-3) Soldering pattern

Example of patterning design indicated as follows. In an actual design, please consider mounting density, the reliability of soldering, etc. and check whether performance is optimal.

•Soldering pattern

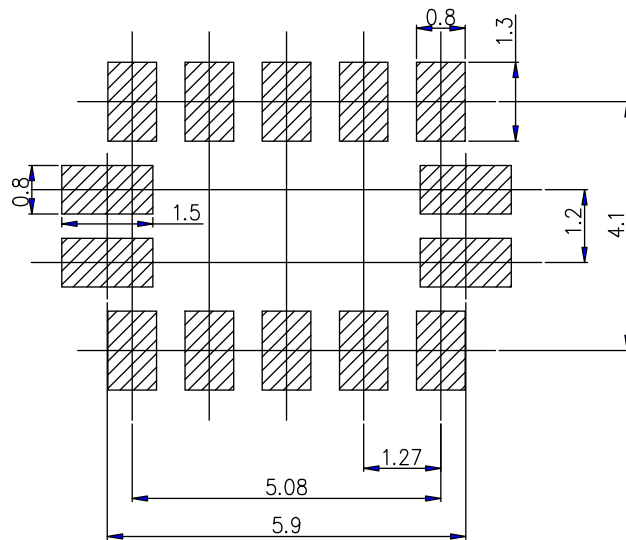

3. Part Number

MG7050EAN 156.250000MHz 4 A C J A N

* Unavailable Combination : xAxJDA and xAxJBA

Model Name Frequency

Aging
 A: Frequency tolerance include 10years aging at 25°C , N: exclude aging
 Operating temperature
 A: 0 °C to +70 °C , B: -20 °C to +70 °C , D: -5 °C to +85 °C
 Frequency tolerance
 J: $\pm 50 \times 10^{-6}$, L: $\pm 100 \times 10^{-6}$
 Supply voltage
 C: 3.3 V , D: 2.5 V
 "A" Fixed
 Number of outputs
 2: 2-outputs , 4: 4-outputs

4. Timing chart

1) Output waveform

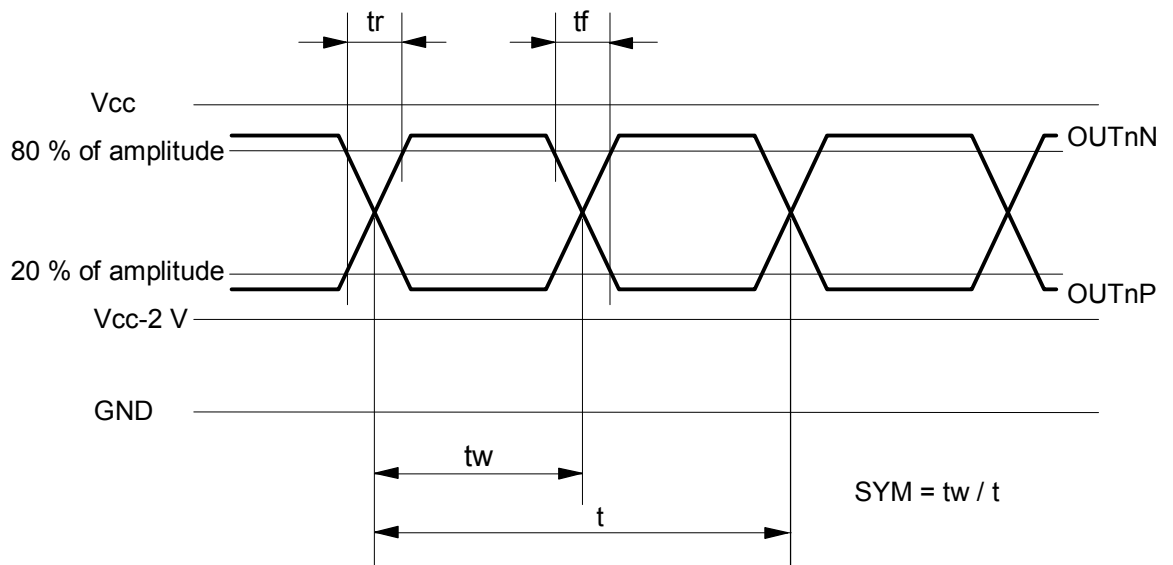

2) OE function and timing

OE input level	Oscillation	Outputs
"H"	Enable	Enable : specified frequency
"L"	Enable	Disable : high impedance

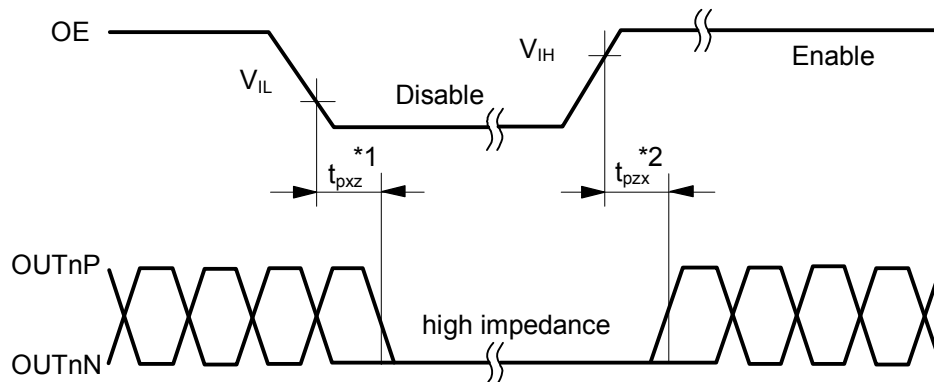

*1 The time taken from OE=V_{IL} to OUTnP/OUTnN=Disable (high impedance).

*2 The time taken from OE=V_{IH} to OUTnP/OUTnN =Enable.

* OE input voltage must be lower than V_{cc}. Note that rise-up time of OE input voltage must not be shorter than the rise-up time of supply voltage.

5. Reference circuit

5-1) Test circuit

2-outputs

Case 1

•Vcc=3.3 V

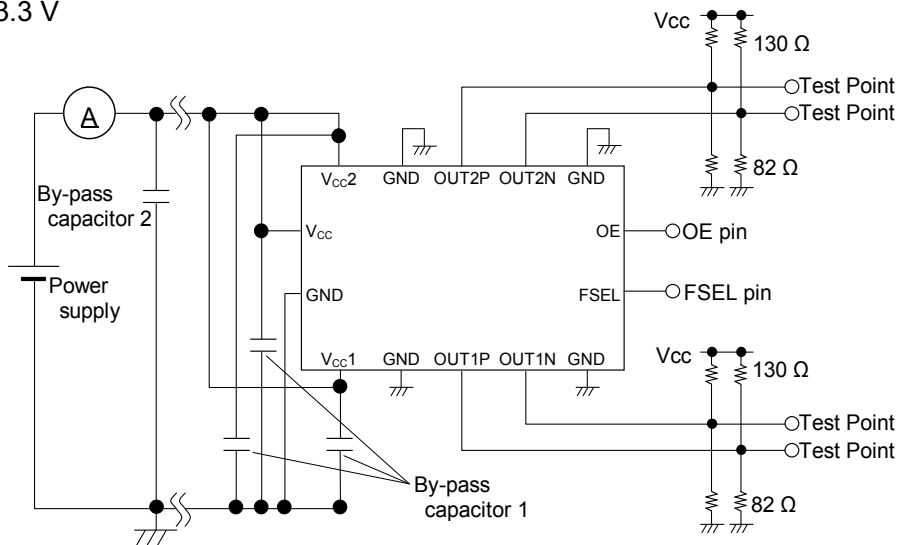

•Vcc=2.5 V

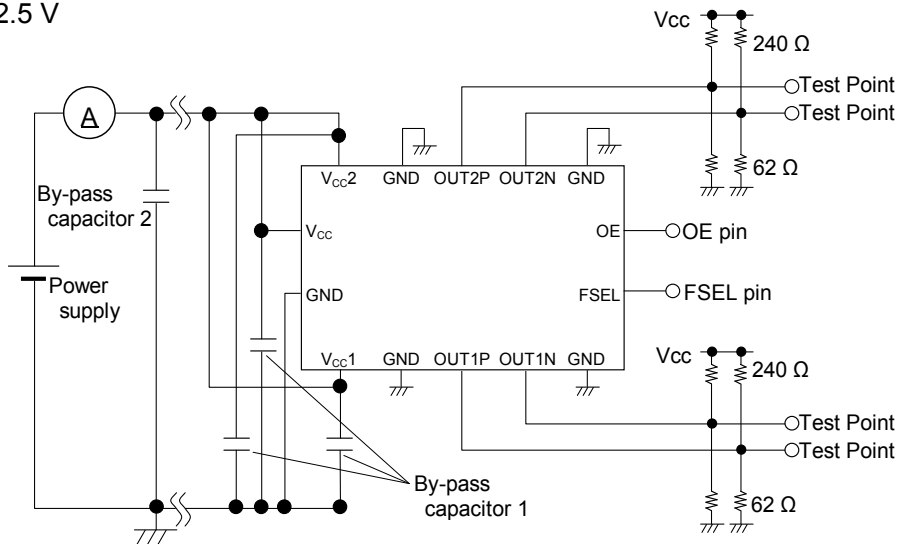

Case 2

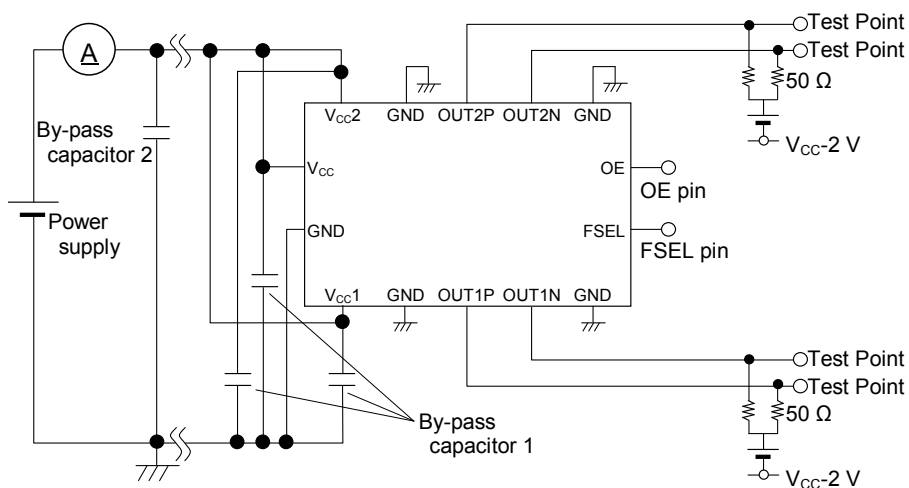

4-outputs

Case 1

•Vcc=3.3 V

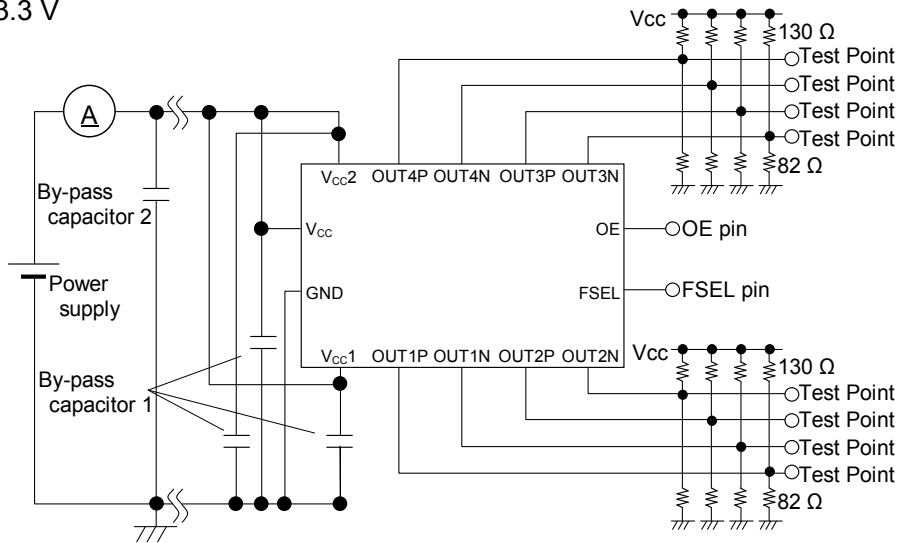

•Vcc=2.5 V

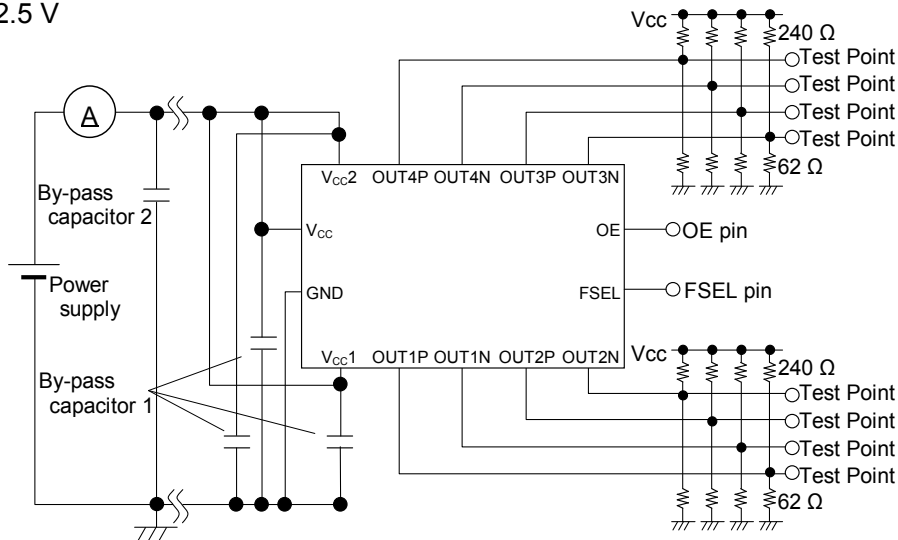

Case 2

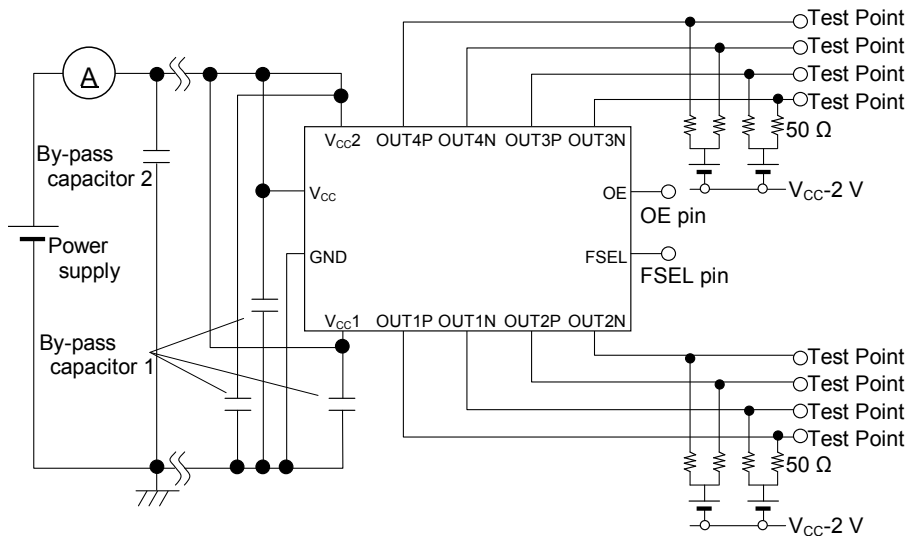

5-2) PCB layout (multilayers, with Vcc and GND layer inside)

2-outputs : Case 1

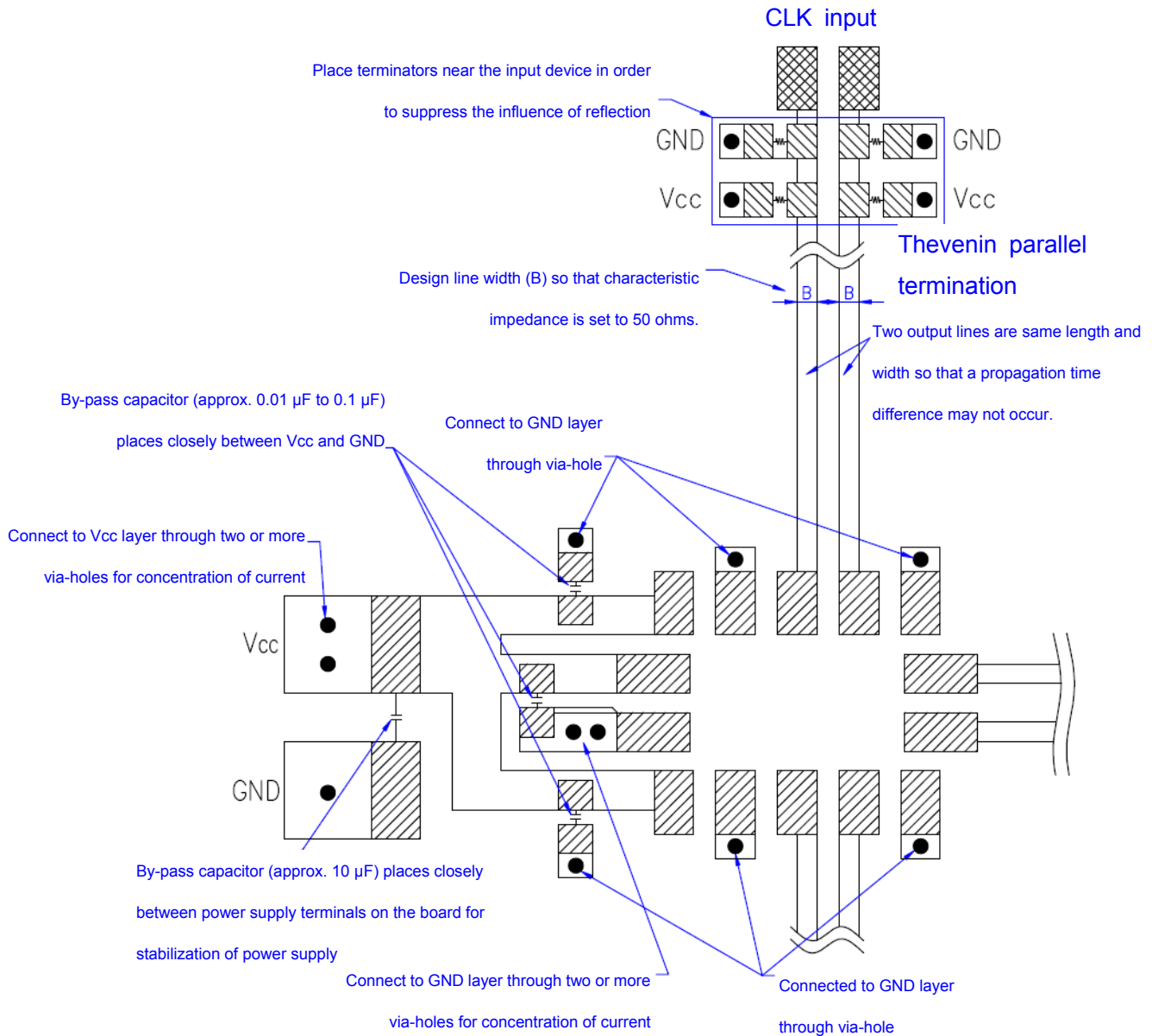

2-outputs : Case 2

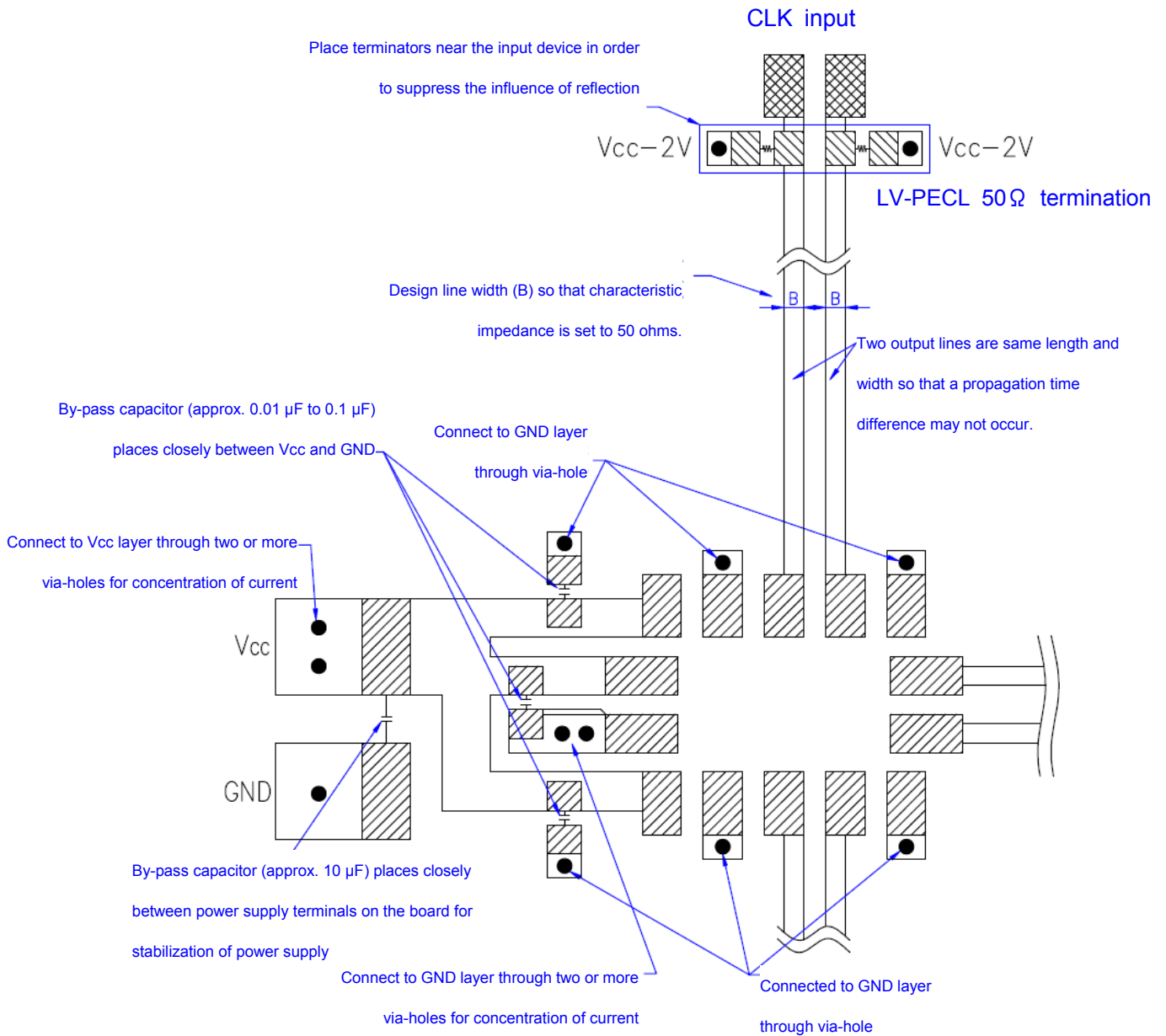

4-outputs : Case 1

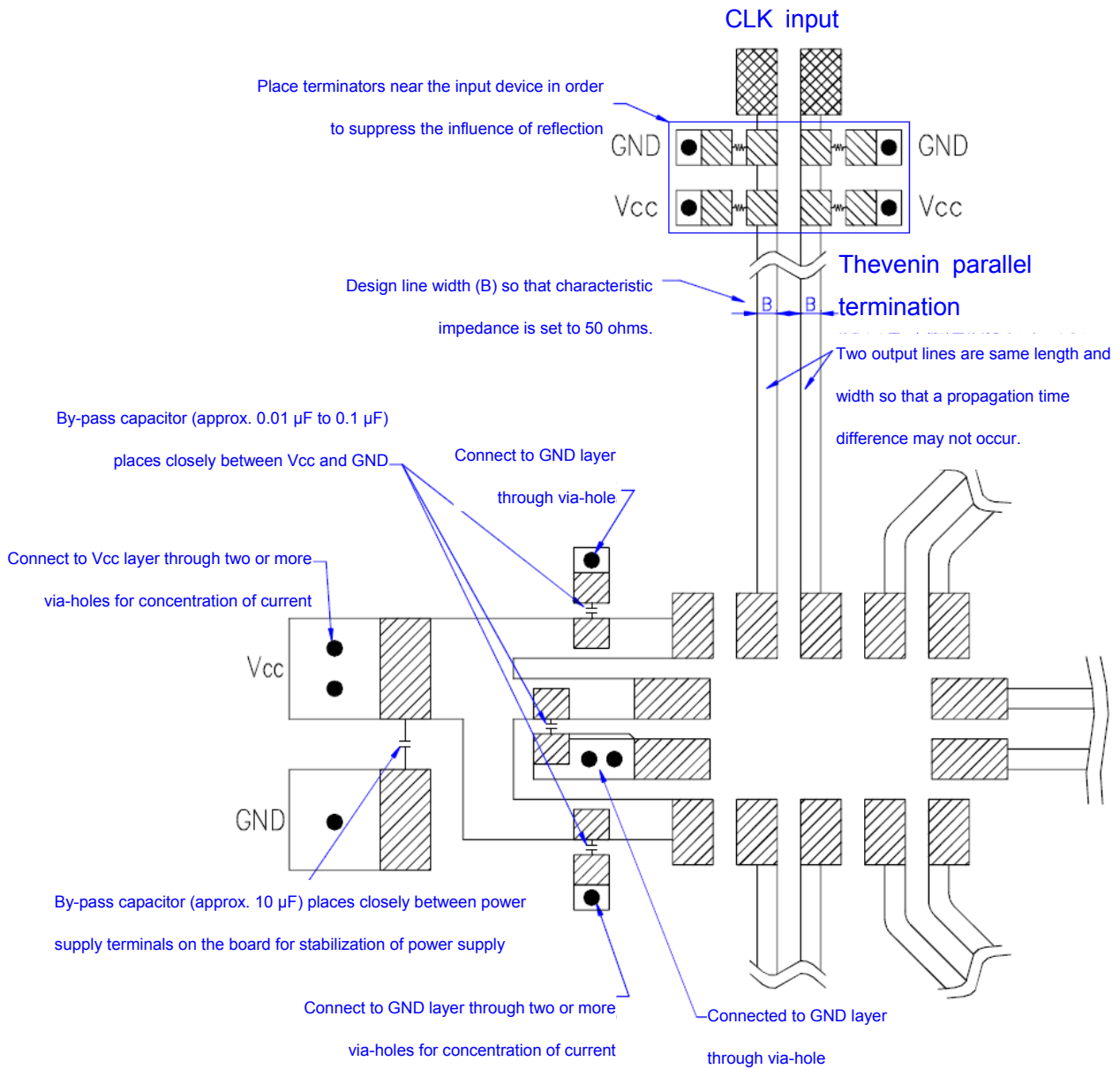

4-outputs : Case 2

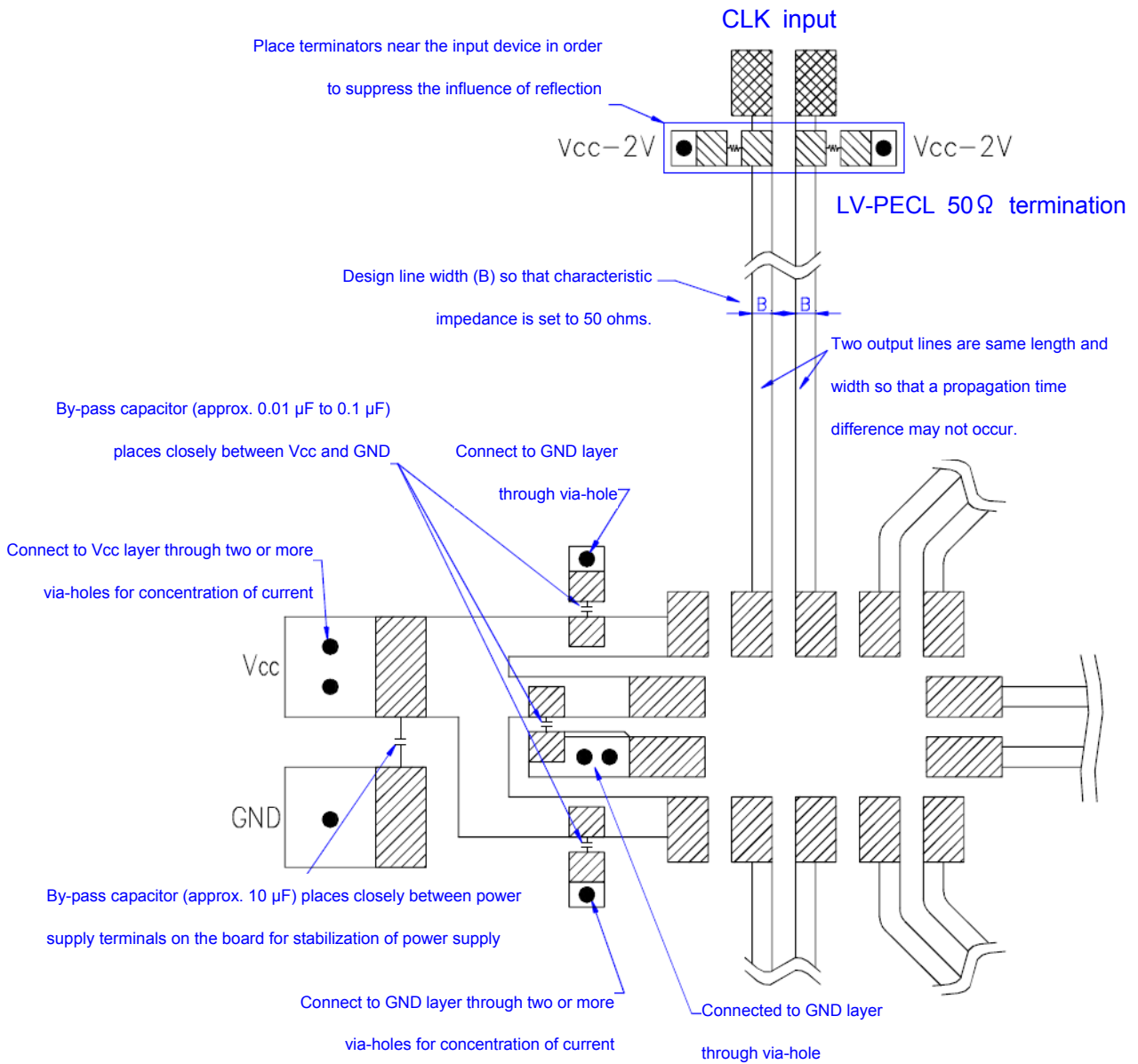

6. Handling precaution

****Quartz parts are precision parts. Please handle carefully paying attention to the next points****

- 1) This device contains a SAW resonator, so please do not expose to excessive shock or vibration.
- 2) Ultrasonic cleaning can be used on this product, however, since the oscillator might be damaged under some conditions, please exercise caution in advance.
- 3) An automatic insertion is available, however, the internal SAW resonator might be damaged in case that too much shock or vibration is produced mechanically. Be sure to check your machine condition in advance.
- 4) This device is made with C-MOS IC.
Please take necessary precautions to prevent damage due to electrical static discharge.
- 5) We recommend placing a 0.01 μ F to 0.1 μ F capacitor closely between Vcc(#13pin), Vcc1(#1pin), Vcc2(#12pin) and GND(#2pin) to obtain stable operation and protect against power line ripple.
- 6) Vcc and GND pattern shall be as large as possible so that high frequency impedance shall be small.
- 7) The metal part of the surface (metal cap) is connected to GND #2pin.
Please take necessary precautions to prevent short circuit to GND by contact with the metal cap.
- 8) Start up time (0 to 90% Vcc) of power source should be more than 150 μ s and slew rate should be less than 19.8 mV/ μ s.
We don't recommend to power on from intermediate electric voltage or extreme fast power on.
Those powering conditions may cause no oscillation or abnormal oscillation.
- 9) Please design the output lines by characteristic impedance 50 Ω and try to make the output lines as short as possible.
A long output line may cause irregular output.
- 10) Other high level signal lines may cause incorrect operation, so please do not place high-level signal line close to this device.
- 11) We recommend to use and store under room temperature and normal humidity to secure frequency accuracy and prevent moisture.
- 12) When not use OE pin connection, please use connecting to Vcc.
We recommend installation of a resistor in between to mitigate effect by surge etc.
- 13) When distributing output signals, please use the clock divider IC (LV-PECL fanout buffer).
- 14) Please arrange LV-PECL terminal resistance with both outputs, even if only one output signal is used.
- 15) DUT's surface temperature may rise from surrounding temperature by self heat-generation. Please confirm a rise in temperature with DUT mounted to an actual substrate, because it may change from the mounting condition.
- 16) Recommendation reflow times are less than 2 times.
In case that this device is reflow soldered on the back side of your circuit board, please carefully verify the device is properly secured to prevent coming detached from card.
- 17) The ripple and the noise included in the supplied power supply might be deteriorated of the noise property of this oscillator.
Please enough consideration to design of power supply.
- 18) The ripple and the noise included in the supplied power supply might be deteriorated of the noise property of this oscillator.
Please optionally add the LC filter circuit.

Soldering method	Good or No good
Reflow soldering (top side)	Good
Reflow soldering (back side)	Please carefully verify the device is properly secured to prevent coming detached from card.
Solder pot (static solder pot / flow solder pot)	No good
Iron soldering	Good

7. Contact

America

Epson Electronics America, Inc.
214 Devcon Drive, San Jose, CA 95112, U.S.A.
Phone: +1-800-228-3964 FAX: +1-408-922-0238

Europe

Epson Europe Electronics GmbH
Riesstrasse 15, 80992 Munich, Germany
Phone: +49-89-14005-0 FAX: +49-89-14005-110

Asia

Epson (China) Co., Ltd.
7F, Jinbao Bldg., No.89 Jinbao Street Dongcheng District, Beijing, China, 100005
Phone: +86-10-8522-1199 FAX: +86-10-8522-1120

Shanghai Branch

High-Tech Building, 900 Yishan Road, Shanghai 200233, China
Phone: +86-21-5423-5577 FAX: +86-21-5423-4677

Shenzhen Branch

12/F, Dawning Mansion, #12 Keji South Road, Hi-Tech Park, Shenzhen, China
Phone: +86-755-2699-3828 FAX: +86-755-2699-3838

Epson Hong Kong Ltd.

Unit 715-723 7/F, Trade Square, 681 Cheung Sha Wan Road, Kowloon, Hong Kong
Phone: (86) 755-26993828 (Shenzhen Branch)
FAX: (86) 755-26993838 (Shenzhen Branch)

Epson Taiwan Technology & Trading Ltd.

14F, No. 7, Song Ren Road, Taipei 110, Taiwan
Phone: +886-2-8786-6688 FAX: +886-2-8786-6660

Epson Singapore Pte., Ltd.

No 1 HarbourFront Place, #03-02 HarbourFront Tower One, Singapore 098633
Phone: +65-6586-5500 FAX: +65-6271-3182

Seiko Epson Corp. Korea Office

5F, KLI 63 Bldg., 60 Yoido-dong, Youngdeungpo-Ku, Seoul 150-763, Korea
Phone: +82-2-784-6027 FAX: +82-2-767-3677